



Nameplate Specifications

Phase	1	Output HP	0.33 Hp
Output KW	0.25 kW	Voltage	115 V
Speed	1725 rpm	Service Factor	1.35
Frame	56Z	Enclosure	Drip Proof
Thermal Protection	Automatic	Efficiency	62 %
Ambient Temperature	40 °C	Frequency	60 Hz
Current	6.1 A	Power Factor	61.5
Duty	Continuous	Insulation Class	B
Design Code	NO DESIGN CODE	KVA Code	M
Drive End Bearing Size	6203	Opp Drive End Bearing Size	6203
UL	Recognized	CSA	Y
CE	N	IP Code	22
Number of Speeds	1		

Technical Specifications

Electrical Type	Split Phase	Starting Method	Across The Line
Poles	4	Rotation	Selective Counterclockwise
Resistance Main	0 Ohms	Mounting	Resilient Base - Extended Studs
Motor Orientation	Horizontal	Drive End Bearing	Ball
Opp Drive End Bearing	Ball	Frame Material	Rolled Steel
Shaft Type	Single Special Extension	Overall Length	9.72 in
Frame Length	5.75 in	Shaft Diameter	0.625 in
Shaft Extension	1.97 in	Assembly/Box Mounting	F1 ONLY
Outline Drawing	A-SS403781- 575	Connection Drawing	A-EE7195

This is an uncontrolled document once printed or downloaded and is subject to change without notice. Date Created:08/20/2024

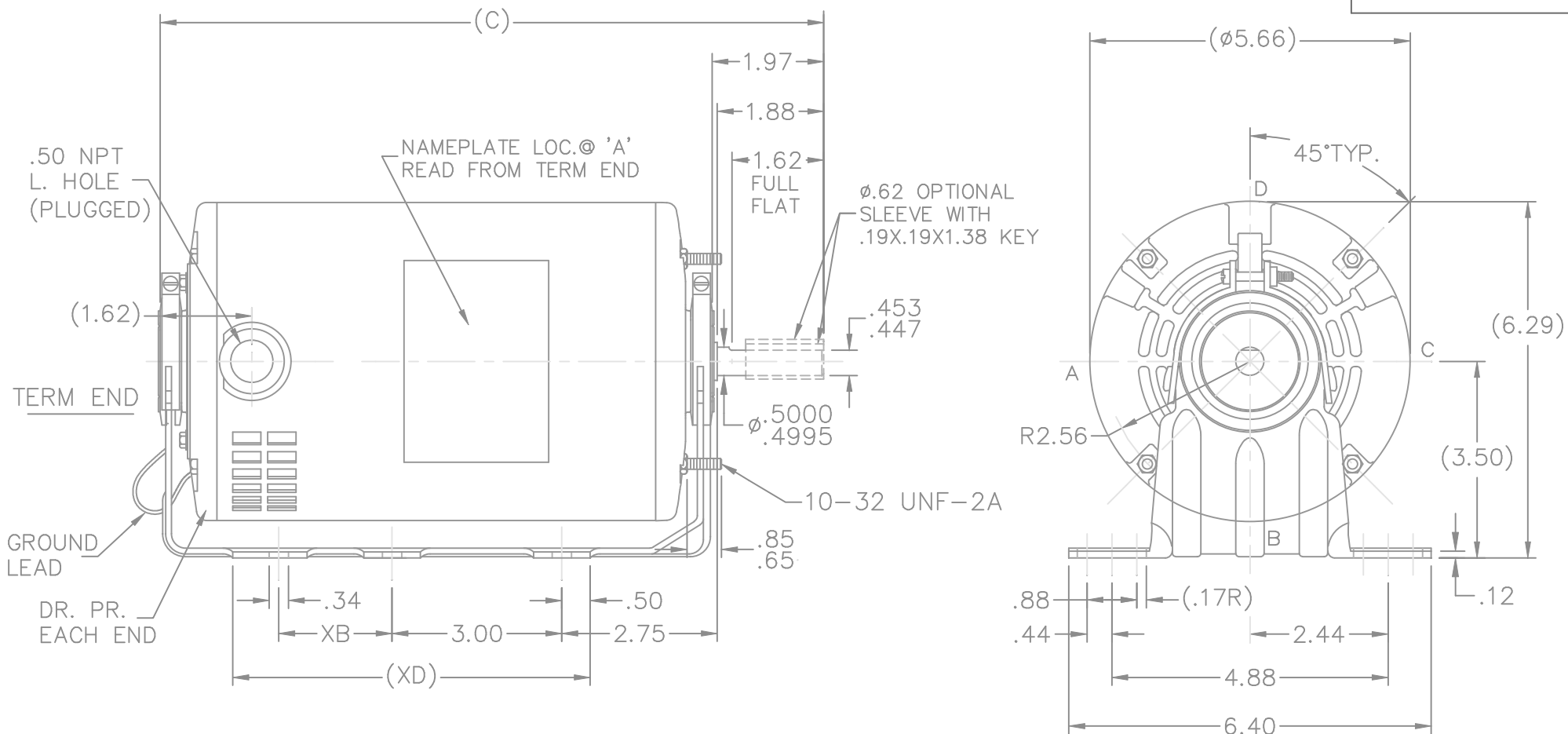

DASH	FRAME	C	XD	XB
550	48	9.47	4.00	0
575	48	9.72	4.31	0
650	48	10.47	5.00	0

				TOLERANCES UNLESS SPECIFIED		 MARATHON ELECTRIC	DRAWN RP 10-07-2008					
				DEC.	INCHES		CHK SP 10-07-2008					
				.X	±.1		APPD NB 10-07-2008					
				.XX	±.03		SCALE 3=8					
				.XXX	±.005		REF					
				.XXXX	±.0005	FMF						
NO.	REVISION	BY & DATE	CHK	ANG	±7'30"	MAT'L.	FINISH	PREV				
			RFP			CAD FILE	ss403781	SIZE	DRAWING NO.	PAGE	OF	REV.
			DIST	WP				A	SS403781			

THIS DRAWING IN DESIGN AND DETAIL IS OUR PROPERTY AND MUST NOT BE USED EXCEPT IN CONNECTION WITH OUR WORK ALL RIGHTS OF DESIGN AND INVENTION ARE RESERVED THIS IS AN ELECTRONICALLY GENERATED DOCUMENT - DO NOT SCALE THIS PRINT

SINGLE VOLTAGE – SPLIT PHASE
 REVERSIBLE ON TERM BOARD
 WITH OVERLOAD PROTECTION

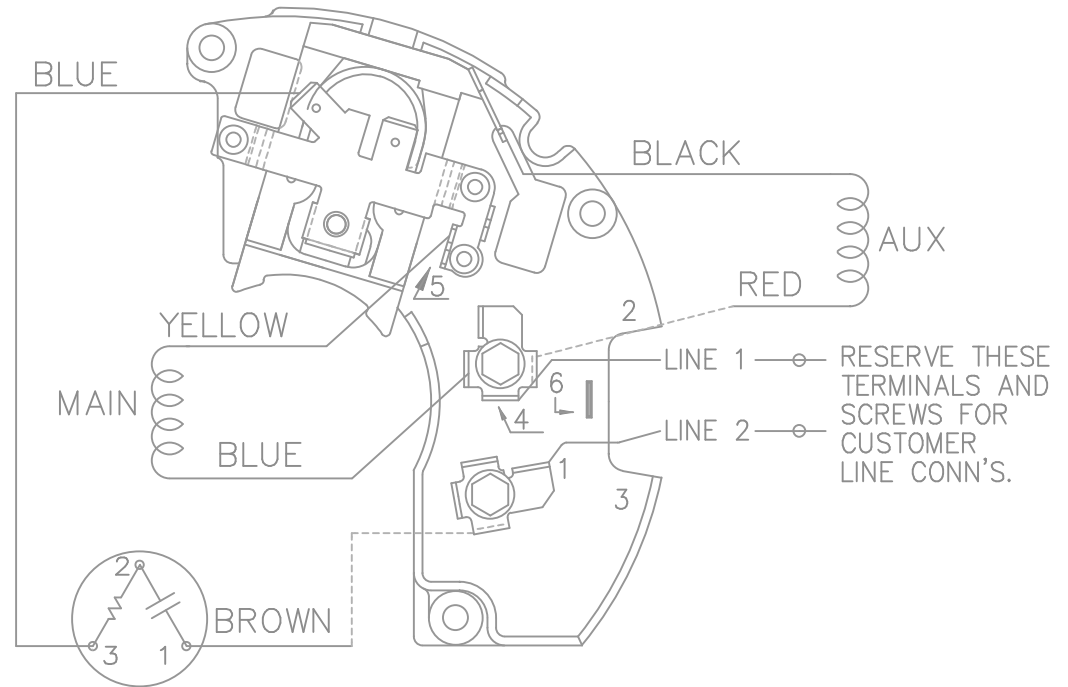
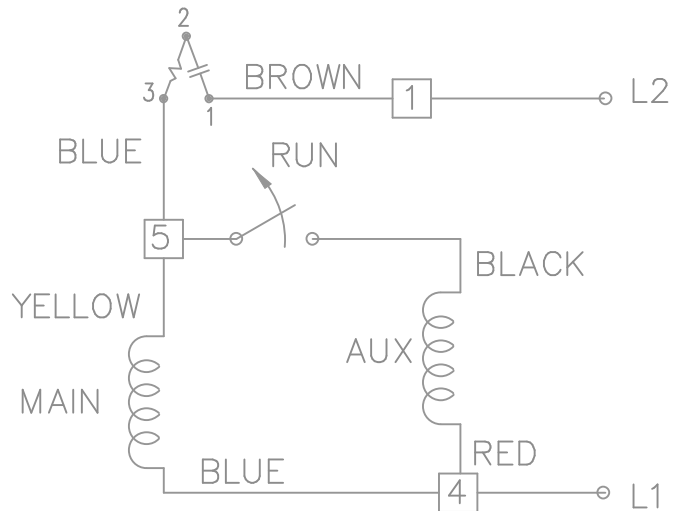

VIEWING TERMINAL END

C.C.W. ROTATION SHOWN.

FOR C.W. ROTATION INTERCHANGE
 YELLOW & BLUE LEADS ON TERM 5 & 4.

DASH LINES INDICATE LEADS CONNECTED
 TO MOTOR SIDE OF SWITCH.

			TOLERANCES UNLESS SPECIFIED			DRAWN ML 01-27-1998	
			DEC.	INCHES		CHK	GK 02-05-1988
5	REDRAWN ON AUTOCAD	RWR 06-15-2004	ML	.X ± -	TITLE CONNECTION DIAGRAM 48 FR. SINGLE VOLTAGE REVERSIBLE	APPD	DRN 03-11-1988
4	REVERSED L1 AND L2 CN19709	AJS 01-16-1995	GK	.XX ± -		SCALE	1=1
3	REVISED LINE 2 LOCATION CN6427	RM 01-28-1991	GK	.XXX ± -		REF	
2	ADDED CUSTOMER CONNECTION NOTE CN6011	BW 08-03-1989	GK	.XXXX ± -		MAT'L.	FMF
NO.	REVISION	BY & DATE	CHK	ANG ± -		FINISH	PREV
THIS DRAWING IN DESIGN AND DETAIL IS OUR PROPERTY AND MUST NOT BE USED EXCEPT IN CONNECTION WITH OUR WORK ALL RIGHTS OF DESIGN AND INVENTION ARE RESERVED THIS IS AN ELECTRONICALLY GENERATED DOCUMENT - DO NOT SCALE THIS PRINT			RFP	CAD FILE ee7195		SIZE	DRAWING NO. PAGE 1 OF 1 REV.
			DIST	LB	A	EE7195	5

** Subject to change without notice.



MARATHON ELECTRIC CORPORATION
TYPICAL PERFORMANCE CURVE for AC MOTOR

Customer

Curve at

115 Volts
60 HZ
0.33 HP

HP 0.33

PHASE 1

Model No 56S17D2048

VOLTS 115

Catalog No B202

HZ 60

RPM 1725

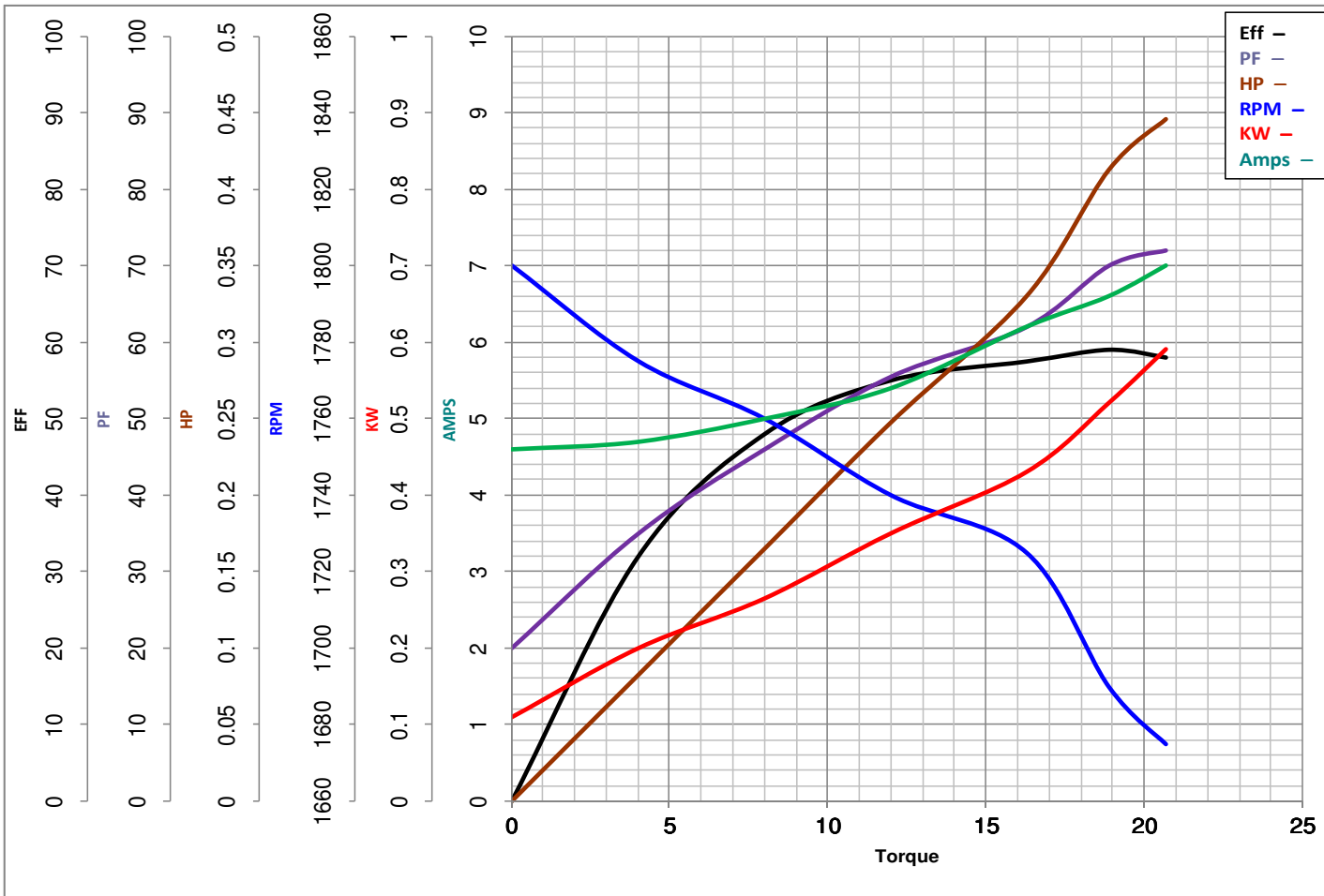

Torque in Oz.Ft

FL TORQUE 16.3 Oz.Ft
BD TORQUE 36.9 Oz.Ft
LR TORQUE 22.9 Oz.Ft

FL AMPS 6.1
PU TORQUE 34.9 Oz.Ft
LR AMPS 31

WINDING SE484121-1

Date 1/25/2019